

C-CHANNEL JAMB

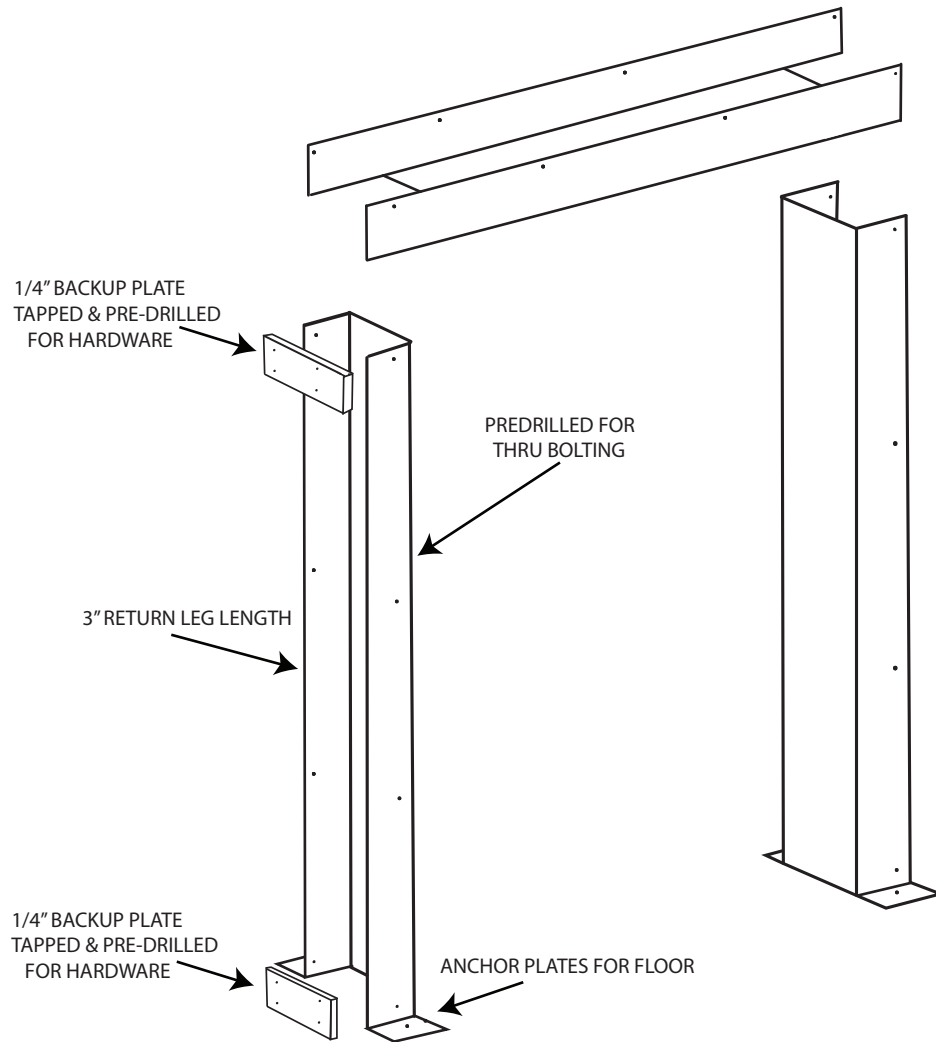

National ACCESS DESIGN LLC
 513-351-3400 fax: 866-300-4539 sales@nationalaccessdesign.com
 NationalAccessDesign.com

C-CHANNEL JAMB SPECIFICATION

Qty. _____

Wall Thickness _____

Type of Wall _____

Finished Opening Size _____

TO CALCULATE A ROUGH OPENING:

Finished Width & Add 1 1/4" _____

Finished Height & Add 5/8" _____

MATERIAL TYPE 14 GAUGE STEEL

Mild Steel Factory Primed

304B-2B Polished Stainless Steel

Charges will be assumed by buyer for changes or cancellations to work in process. Buyer hereby accepts responsibility for all sizes and dimensions. This order will not be processed until all acknowledgement forms are signed and returned.

Specification accepted by: _____

Date: _____

NAD C-CHANNEL JAMB

JOB NAME/LOCATION

CUSTOMER/LOCATION

CUST. ORDER NO.

CUST. PO ORDER NO.